

# HÜBNER Analog-Tachos

LongLife® dc tachometers

## Installation and operating instructions

**HÜBNER**  
ELEKTROMASCHINEN AG  
BERLIN

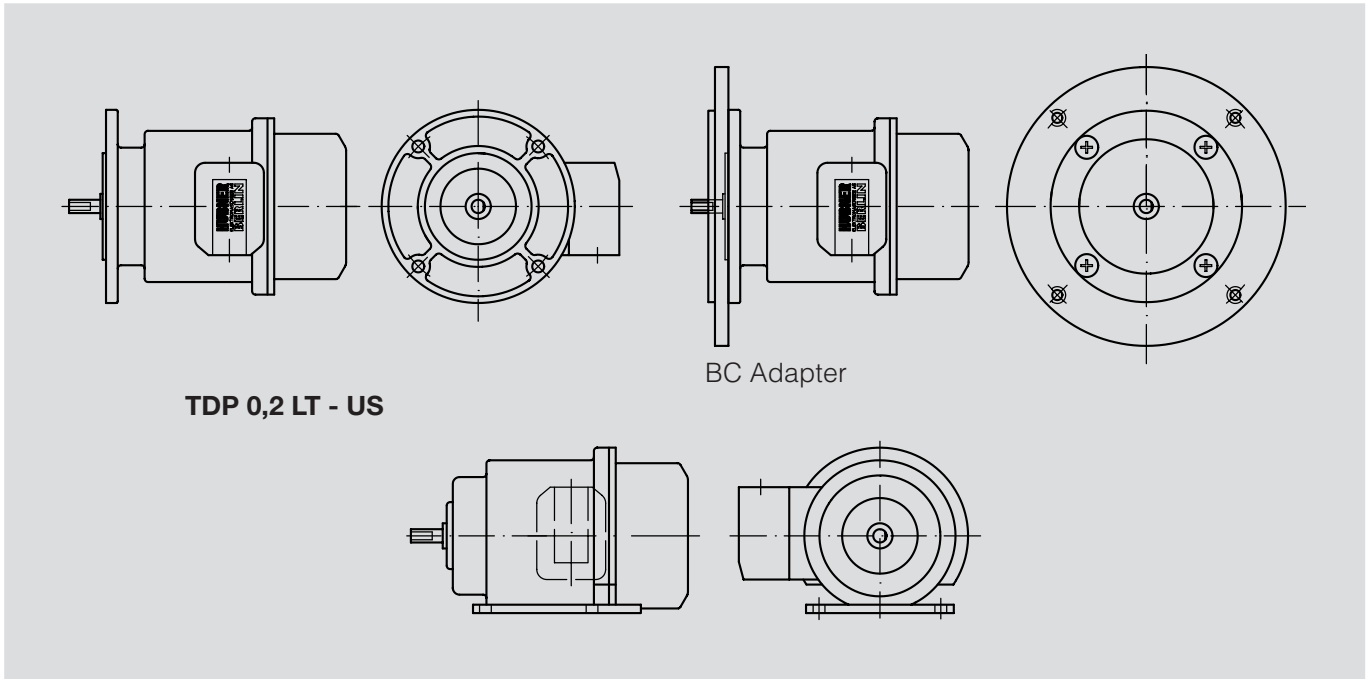

TDP 0,2 LT - US

BC Adapter

### Important Notice

- Analog-Tachos (dc tachometers) are **precision rotary speed measurement devices** which must be handled by skilled personnel and with care during transportation, mounting and operation.
- The Analog-Tachos TDP 0,2 LT - US with solid shaft are driven via a torsionally stiff, flexible coupling (e.g. Hübner spring disk coupling K35) which should be slid onto the shaft with minimum axial pressure. If shaft eddy currents occur in the motor shaft, it is recommended to use an insulated coupling like the Hübner spring disk coupling K 35 with insulated hub.
- **Hammering** the coupling on the shaft is not permitted because the ball bearings may be damaged.
- Shafts with a key are dynamically balanced in the factory. Therefore drives elements like couplings or pulleys must be balanced on a smooth mandrel without key.
- LongLife® dc tachogenerators are **free of maintenance**. The expected **operating life** is governed by the **ball bearings**, which are manufactured with a permanent lubrication. Repair or maintenance requiring dismantling should be carried out by the manufacturer.
- The devices are manufactured according to **quality standard** DIN ISO 9001, **EU Declaration of Conformity** meeting Council Directive 89/336/EEC art. 10 and annex 1 (EMC Directive).

| Type            | Pairs | Carbon brushes           |                   | Ball bearings (1 set) |      |            |
|-----------------|-------|--------------------------|-------------------|-----------------------|------|------------|
|                 |       | Part no.                 | *min. length (mm) | DE                    | NDE  | Part no.   |
| TDP 0,2 LT - US | 2     | S 7 / H 7:<br>ET.02.1057 | 5,3               | 6002                  | 6000 | ET.05.1015 |

\* When the minimum brush length is reached, the brushes should be replaced and the commutator area should be cleaned with dry compressed air in order to ensure proper operation.

Detailed specifications of all individual products are available.

# LongLife-DC-Tachometer

## TDP 0,2 LT - US

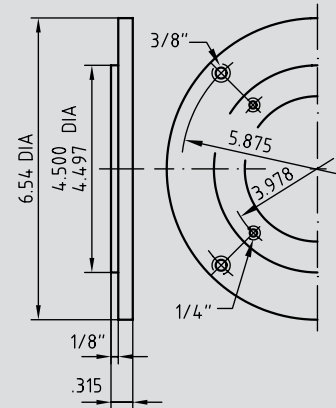
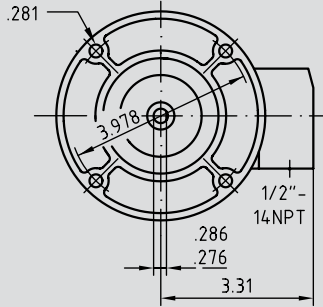
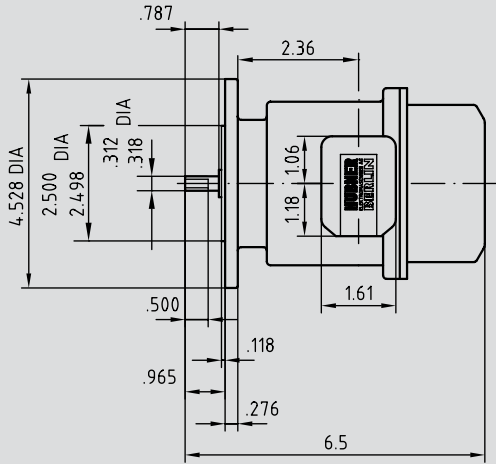

BC Adapter

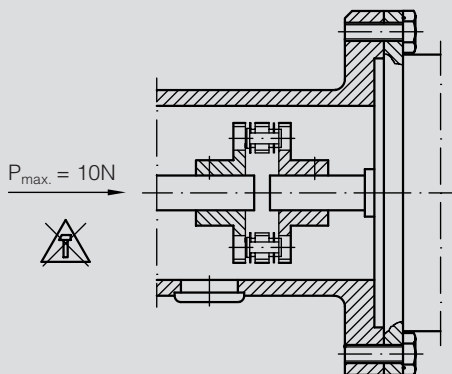
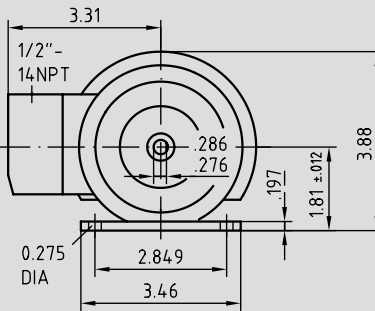
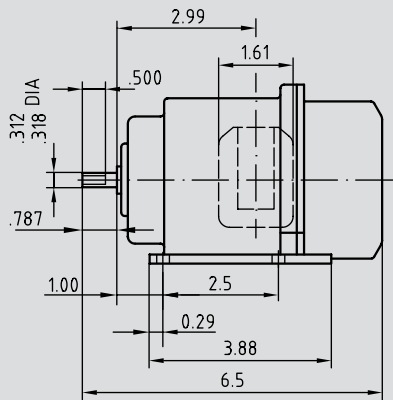

Max. admissible mounting errors

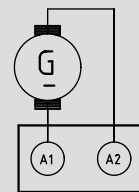
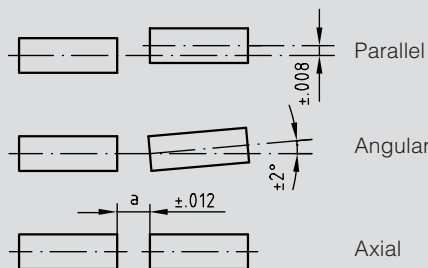

Polarity for clockwise rotation of the drive, viewing mounting face