



■ Output channels	8
■ Opto-electronic scanning	9
■ Dual scanning	9
■ Incremental disks	9
■ Number of slots	9
■ Signal level	10
■ Mark-space ratio	11
■ Pulse offset	11
■ Rise time	11
■ Max. load current	12
■ Peak current	12
■ Max. cable length	12
■ Power loss	12
■ Sinus-Tachos (sinewave encoders)	13
■ Sinus-Tachos with absolute track	15
■ Sinus-Tachos with acceleration sensor	16
■ Absolute multi-turn encoder	16
■ Supply voltage	17
■ Reverse polarity protection	17
■ Protection from voltage spikes	17
■ Electromagnetic Compatibility (EMC)	17
■ Housings	18
■ Ball bearings	18
■ Bearings at both ends	18
■ Rear shaft	18
■ Protection from shaft currents	18
■ Digital-Tachos without bearings	19
■ Temperature range	19
■ Vibration and shock resistance	19
■ Protection class	20
■ Cable connection	20
■ EURO-flange® B10	20
■ Explosion proof	20
■ ISO 9001 certificate	20
■ EU Declaration of Conformity · CE	21
■ Coupling	21



Figure 1: HÜBNER Digital-Tachos with squarewave and sinewave signals...

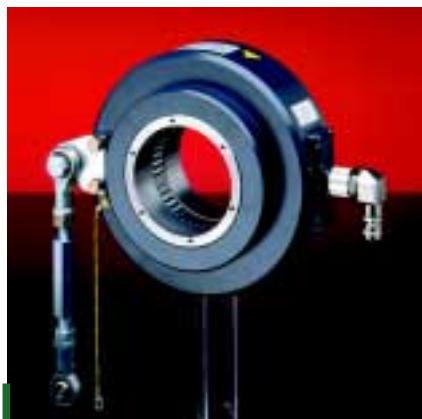

Figure 2: ...are mechanically and electronically rugged in all sizes (HeavyDuty® technology).

Digital-Tachos (incremental encoders) and **Sinus-Tachos** (sinewave encoders) are used in measurement, drive and automation engineering as transducers to convert the mechanical parameters "rotational speed" or "position" of a drive into an electrical signal. For this purpose an **incremental disk** with radial translucent slots is used which is scanned opto-electronically. The number of slots determines the resolution (pulses per turn).

Digital-Tachos output a series of **square-wave** pulses (➔ Figure 3) when the shaft is turned, the number of pulses being proportional to the angle turned. The number of pulses counted from a reference point (marker pulse) is a direct measure of the angle or **position**, whereas the **rotational speed** is calculated from the number of pulses per unit time.

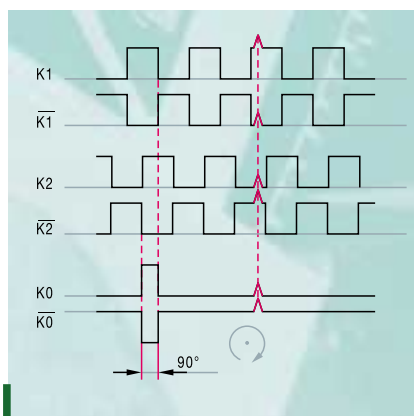

Figure 3: Squarewave signals from a double channel Digital-Tacho with marker pulse and inverted signals for suppressing superimposed interference (➔ page 24).

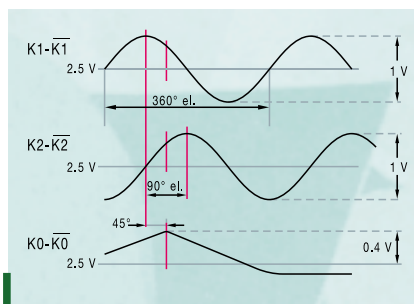

Figure 4: Sinewave signals from a Sinus-Tacho can be interpolated due to their continuous gradient between the zero transitions (➔ page 13).

Sinus-Tachos offer a series of **sinewave cycles** (➔ Figure 4) with the possibility of deriving **interpolated values** from each cycle of the sinewave between the zero transitions so that information is continuously available to the controller.

The precision of the **acquisition of the actual value** is decisive for the accuracy of the **closed loop control system**. HÜBNER Digital-Tachos with squarewave and sinewave signals are characterized, along with high **accuracy**, by a particularly high degree of mechanical and electrical **ruggedness** making them suitable for use in harsh environments. Each device complies with the criteria of **HeavyDuty®** technology relevant to its application class.

Output channels

- **Single channel** Digital-Tachos with one output signal K1 are used when the drive only rotates in one direction or it is not necessary to detect the direction of rotation.
- **Dual channel** Digital-Tachos with two output signals offset by 90°, K1 and K2, can detect the direction of rotation: in the case of clockwise rotation, viewing the shaft, signal K1 leads signal K2.
- **Dual channel** Digital-Tachos with a **marker pulse** (reference signal): the additional marker pulse K0, synchronized with the two output signals K1 and K2 (➔ Figure 3 and 4), enables counting full revolutions.
- **Inverted signals** increase the signal to noise ratio of the signal transmission (➔ *Optimum Signal Transmission*, page 24): In addition to the output signals K1, K2, K0, the inverted output signals $\bar{K1}$, $\bar{K2}$ and $\bar{K0}$ are available (➔ Figure 3 and 4, standard for TTL squarewave and sinewave signals).

Opto-electronic scanning

Opto-electronic scanning is optimized by HÜBNER as follows:

- **Opto-ASICs** are preferred in Digital-Tachos with squarewave signals due to their compact size when permitted by the number of slots and the maximum switching frequency of 120 kHz.
- **Individually optimized scanning electronics** is preferred for Digital-Tachos having a large number of slots or with sinewave output signals. The light emitting diode (LED), the brightness of which is regulated, and the push-pull photoelectric receivers are the basis for constant output signals, even under the effects of temperature or ageing. This is particularly important for Sinus-Tachos with their high requirements on the quality of sinewave signals. The maximum switching frequency (bandwidth) is 250 kHz.
- The **life time** of the **light emitting diode (LED)** is in excess of 100,000 hours. The half-value time, when the light intensity falls to 50 %, is compensated for over a wide range by the brightness controller.

Double scanning

Scanning with two isolated systems is available in two forms:

- Two **radially opposed scanning systems** scan a *common* incremental disk: **redundancy** (➔ Figure 5). This option can be incorporated on some Digital-Tachos.
- Two **axially displaced scanning systems** with *separate* incremental disks arranged axially one behind the other, the number of slots can be different: **twin encoders** (➔ Figure 6). (➔ *Combinations Expand the Range of Applications* on page 23).

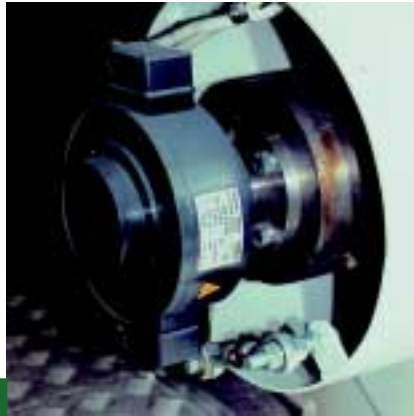

Figure 5: Redundant scanning, the HOG 16 on a 2,600 kW drive as example.

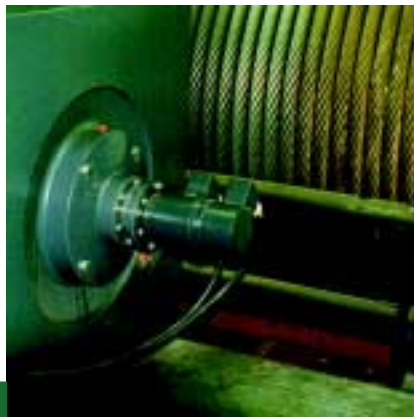

Figure 6: Twin encoder, the POG 9 G on a 450 kW drive as example.

Incremental disks

The incremental disks fitted to HÜBNER Digital-Tachos are made of **metal** whenever possible for reasons of ruggedness. For smaller numbers of slots the disks are etched, for higher numbers of slots the disks are manufactured using a galvanic accumulation process of high accuracy.

Glass disks with a chrome layer are used for large numbers of slots. Plastic disks are reserved for special cases.

The **variation in the position** of the pulse edges from the nominal value (jitter) within one revolution of the incremental disk is in the range of $\pm 1/10$ (metal) and $\pm 1/20$ (glass) of the signal period.

Number of slots

The number of slots z on the incremental disk depends on the **switching frequency** f_{\max} of the opto-electronic circuit and the **rotational speed** n_{\max} :

$$z \leq \frac{60 \cdot 10^3 \cdot f_{\max}}{n_{\max}}$$

- z : number of slots
- f_{\max} : max. switching frequency [kHz]
- n_{\max} : max. speed [rpm]

● Example:

- $f_{\max} = 120$ kHz
- $n_{\max} = 6,000$ rpm
- ➔ $z = 1,200$ slots

In respect of **quasi-continuous** control behaviour actual information of the speed should always be available. This means that at least one edge of the squarewave changes during the sampling period T_A of the control. Consequently, for a given number of slots z the **minimum speed** follows:

$$n_{\min} = \frac{60 \cdot 10^6}{z \cdot 2k \cdot T_A}$$

- n_{\min} : min. speed [rpm]
- z : number of slots
- k : number of channels
- T_A : sampling period [μ s]

● Example:

- $z = 1,024$ slots
- $k = 2$ (double channel)
- $T_A = 250$ μ s
- ➔ $n_{\min} \approx 58$ rpm

Below this speed, reductions in the quality of smooth running must be expected.

Sinus-Tachos offer an advantage due to their continuous gradient of signals (➔ page 13).

Signal levels

The signal levels are based on the required length of the cable and the signal to noise margin:

■ HTL technology

High voltage Transistor Logic with **power transistors** for the transmission of signals over long cables

(➡ Figure 7):

- Supply (battery) voltage
 $V_B = +9 \dots 30 \text{ V}$
- Logic levels $V_{Low} \leq 1.5 \text{ V}$
 $V_{High} \geq V_B - 3.5 \text{ V}$
- Signal to noise margin
 $V_S \approx V_B / 2$
- Max. load current per channel
 $I_{source} = I_{sink} \approx 60 \text{ mA}$
- Peak current per channel
 $i_{max} \approx 300 \text{ mA}$
- Continuous short circuit protected

■ **HTL ... I** technology with **inverted signals**: For the transmission of signals over very long cables, HTL technology is also available with inverted signals as an option. Twice the number of power transistors are provided (➡ Figure 8).

- Signal to noise margin
 $V_S \geq V_B - 5 \text{ V}$

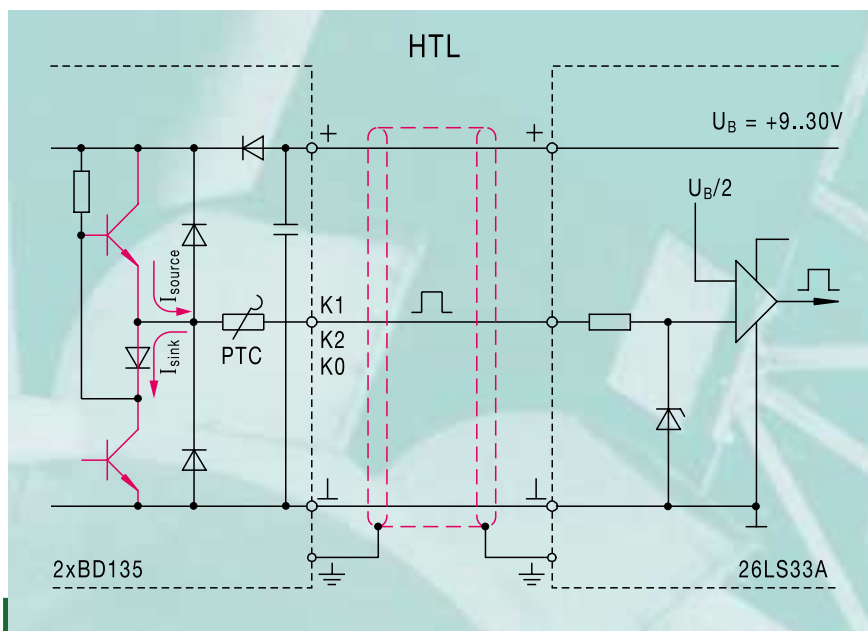

Figure 7: HTL technology with power transistors for transmitting signals over long cables subject to interference.

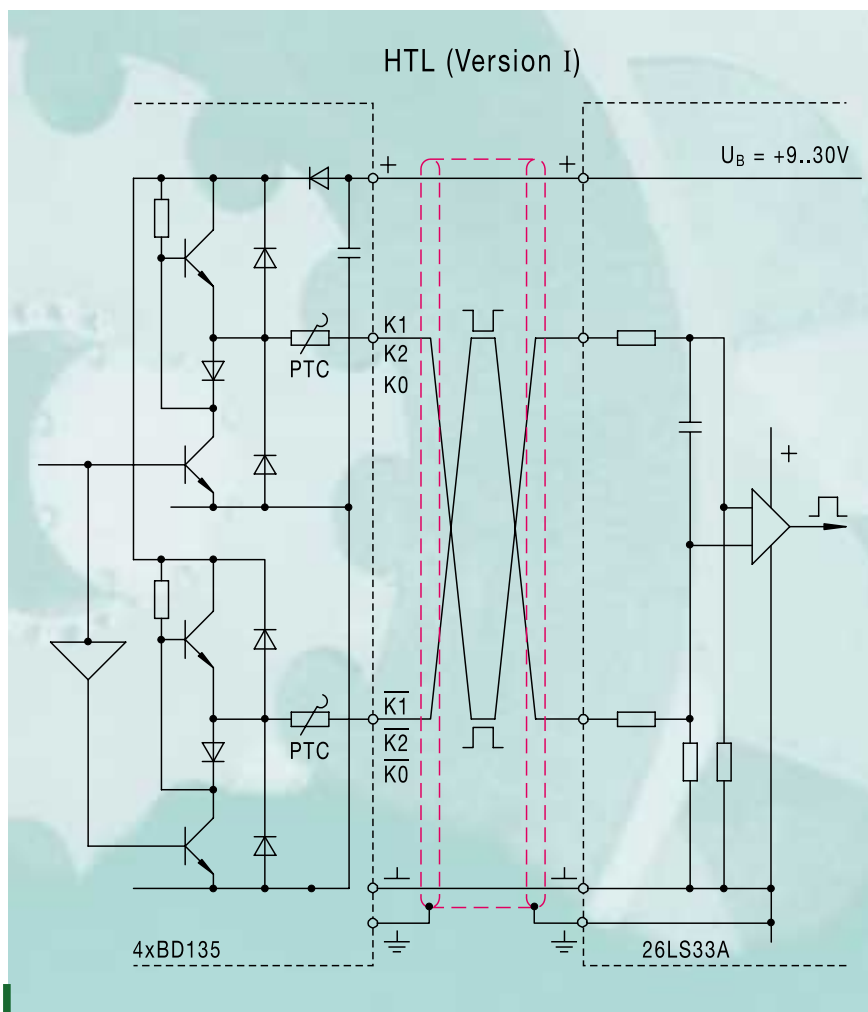

Figure 8: HTL technology with inverted signals: for the best possible transmission reliability.

HTL technology, version C

High voltage Transistor Logic with **line driver IC** for transmitting signals over longer cables (➡ Figure 9):

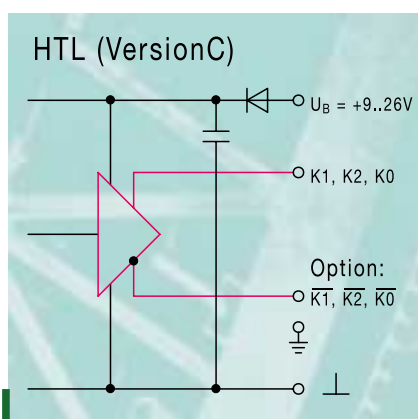

Figure 9: HTL technology, version C, with line driver IC.

- Supply (battery) voltage $V_B = +9 \dots 26 \text{ V}$
- Logic levels $V_{Low} \leq 3 \text{ V}$
 $V_{High} \geq V_B - 3.5 \text{ V}$
- Signal to noise margin $V_S \approx V_B / 2$
- Max. load current per channel $I_{source} = I_{sink} \approx 60 \text{ mA}$
- Peak current per channel $I_{max} \approx 150 \text{ mA}$
- Continuous short circuit protected

HTL technology, version CI, with inverted signals:

For transmitting signals over long cables, the HTL technology, version C, is also available with inverted signals. The increased power loss in the line driver IC limits the peak current.

- Signal to noise margin $V_S \geq V_B - 6.5 \text{ V}$

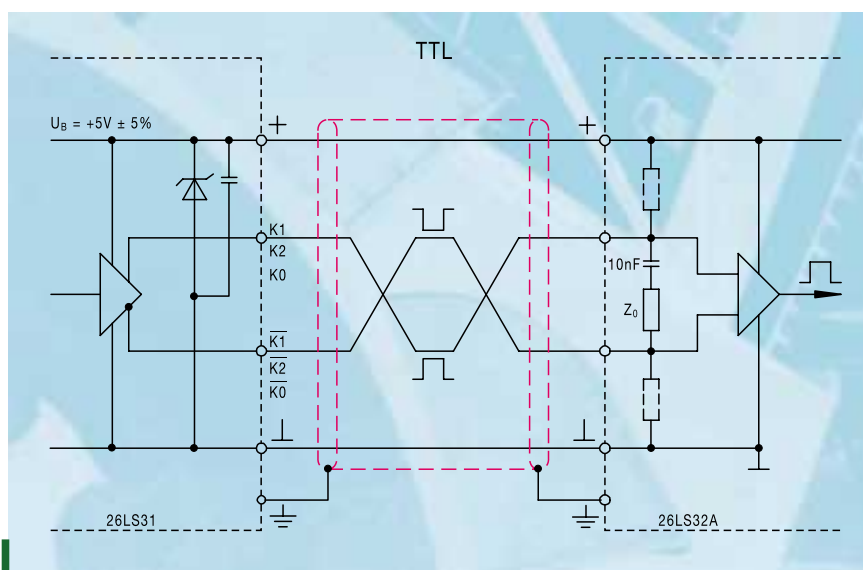

Figure 10: TTL technology meeting the RS-422 interface standard.

TTL (Version R)

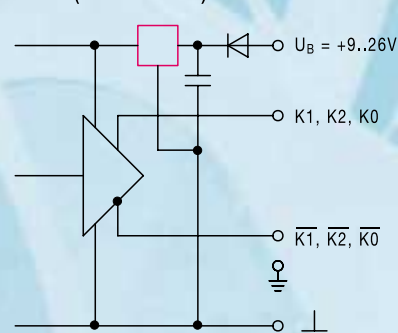

Figure 11: TTL technology, version R, with internal voltage regulator.

TTL technology

Transistor Transistor Logic with **inverted signals** meeting the **RS-422 interface standard** and line driver IC for transmitting signals over shorter cables (➡ Figure 10):

- Supply (battery) voltage $V_B = +5 \text{ V} \pm 5 \%$
- Logic levels $V_{Low} \leq 0.5 \text{ V}$
 $V_{High} \geq 2.5 \text{ V}$
- Signal to noise margin $V_S \geq 2 \text{ V}$
- Max. load current per channel $I_{source} = I_{sink} \approx 25 \text{ mA}$
- Peak current per channel $I_{max} \approx 75 \text{ mA}$
- Short circuit protected for 10 s

TTL technology, version R

TTL technology, additional with internal **voltage regulator**

(➡ Figure 11):

- Supply (battery) voltage $V_B = +9 \dots 26 \text{ V}$

Mark-space ratio

The mark-space ratio of the squarewave pulses (*low to high* ratio) varies from 1 : 1 by $\leq \pm 20 \%$.

For sinewave signals a variation of the ratio 1 : 1 creates a dc offset.

Phase offset

The phase offset between squarewave pulses K1 and K2 in two channel Digital-Tachos may vary from 90° by $\leq \pm 20^\circ$.

Rise time

The rise time on HTL and TTL squarewave pulses is the same:
 $dv/dt = 10 \text{ V}/\mu\text{s}$.

Max. load current

The maximum load current

$I_{\max} = I_{\text{source}} = I_{\text{sink}}$ (➔ Figure 7 on page 10) can flow continuously:

... as **DC** when the Digital-Tacho is at standstill or

... as **AC** (effective value) in the form of squarewave pulses and sinewave signals.

Peak current

The peak current $i_{\max} = \hat{I}_{\text{source}} = \hat{I}_{\text{sink}}$ of the line driver outputs is decisive for the rapid charging and discharging of long cables. In the case of the HTL technology, the cables are not terminated with their characteristic impedance Z_0 due to the power loss (➔ *Optimum Signal Transmission*, page 24). The then dominating **cable capacitance**

$$C = C_K \cdot l$$

- C_K : capacitance per meter
- l : cable length

loads the upper line driver transistor at the start of charging, and the lower line driver transistor at the start of discharging (➔ Figure 7 on page 10) with the **peak current**

$$i_{\max} = C \cdot dv/dt$$

- C : cable capacitance
- dv/dt : voltage rise time

● Example:

- $C_K = 100 \text{ pF/m}$
- $l = 150 \text{ m}$
- $dv/dt = 10 \text{ V}/\mu\text{s}$
- ➔ $i_{\max} = 150 \text{ mA}$

HÜBNER Digital-Tachos in standard HTL technology with power transistors are designed for peak currents of **$i_{\max} = 300 \text{ mA}$** .

Max. cable length

For the border line where only the sinewave fundamental waveform is left from the squarewave pulses and the cable can just be charged at the signal frequency f to the logic level V_{High} , and subsequently discharged, the order of magnitude of the **maximum cable length** is

$$l_{\max} = \frac{I_{\max}}{f \cdot \pi \cdot V_{\text{High}} \cdot C_K}$$

- I_{\max} : max. load current
- f : signal frequency
- V_{High} : logic level V_{high}
- C_K : capacitance per meter

● Example:

- $I_{\max} = 60 \text{ mA}$
- $f = 50 \text{ kHz}$
- $V_{\text{high}} = 30 \text{ V}$
- $C_K = 100 \text{ pF/m}$
- ➔ $l_{\max} \approx 130 \text{ m}$

For a **given cable length l** , consideration must be given to the signal frequency f or the speed n or the signal level V_{High} , amongst other factors.

In the case of **HTL technology**, the maximum load current I_{\max} is extremely important for the transmission of a high signal level V_{High} over cables of length l . This was recognized by HÜBNER back in 1978 and taken into account in the layout of the HTL line drivers.

In the case of the **TTL technology**, the characteristic impedance of the cable $Z_0 \approx 125 \Omega$ defines the current required, the current is independent of the cable length. The maximum cable length, however, is limited by cable losses and internal and external interference (➔ *Optimum Signal Transmission*, page 24).

Power loss

In the case of short-circuit of one of the outputs (➔ Figure 7 on page 10) to ground the upper line driver transistor and in the case of short-circuit to supply voltage V_B the lower line driver transistor is charged with the **maximum power loss**

$$P_{\max} = V_B \cdot i_{\max}$$

- V_B : Supply (battery) voltage
- i_{\max} : peak current

● Example:

- $V_B = 30 \text{ V}$
- $i_{\max} = 300 \text{ mA}$
- ➔ $P_{\max} = 9 \text{ W}$

For this reason HÜBNER uses **power transistors** as push-pull line drivers in the **HTL standard version**. A PTC is fitted between the cooling fins of the power transistors for monitoring the temperature and limiting short circuit current and thus power loss (➔ Figures 7 and 8 on page 10).

Current limiting is necessary for example in the event of cable damage because all the outputs could be short circuited causing power dissipation to occur that is several times the rated maximum, at least briefly. The removal of heat and the space needed for the power transistors requires a certain minimum housing volume. This volume is available on **HÜBNER HeavyDuty® Digital-Tachos** from the series 9 onwards. Smaller Digital-Tachos with HTL technology or Digital-Tachos with TTL or sinewave technology are fitted with line driver ICs in which the peak current, and thus the maximum power dissipation that can occur is lower (➔ *HTL Technology, Version C*, and *TTL Technology* on page 11, *Sinewave Technology* on page 15). The **internal temperature** of the Digital-Tacho must be taken into account in the selection of the temperature range (➔ *Temperature Range* on page 19).

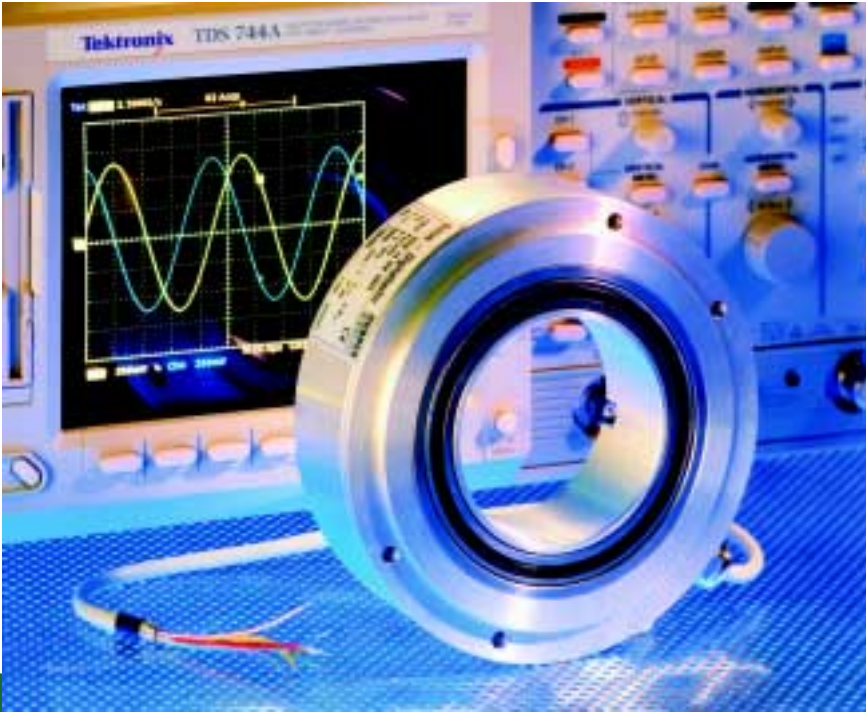

Figure 12: Sinus-Tacho EGS 14 with 1,024 sinewave cycles per turn and large hollow-shaft.

Sinus-Tachos (Sinewave encoders)

Sinus-Tachos, as against Digital-Tachos with squarewave signals, have the advantage that the two 90° offset sinewave cycles (➔ Figure 4 on page 8) are continuous without a time lag.

Using the zero transitions, **interpolation** of the sine and cosine signals makes a large number of intermediate values available. Thus **near zero speeds** can be calculated:

$$n_{min} = \frac{60 \cdot 10^6}{z \cdot I_p \cdot T_A}$$

- n_{min} : min. speed [rpm]
- z : number of slots
- I_p : interpolation
- T_A : scanning cycle [μ s]

● Example (➔ page 9):

- z = 1,024 slots
- I_p = 1,024 times
- T_A = 250 μ s
- ➔ n_{min} \approx 0.2 rpm

The prerequisite for high resolution interpolation are sinewave signals of the highest precision: negligibly small harmonic content, identical amplitude characteristics, low DC offset and a phase offset as close to 90° as possible.

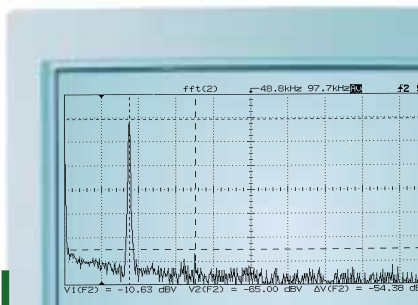

Figure 13: FFT of a HÜBNER LowHarmonics® Sinus-Tacho.

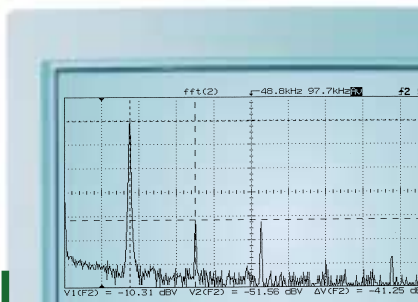

Figure 14: FFT of conventional sinewave encoder: the 2nd and 3rd harmonics are very pronounced.

The HÜBNER **LowHarmonics®** technology provides sinewave signals with a level of purity from harmonics that is unmatched by any other sampling method. The patented principle of operation is as simple as it is effective:

- Illuminated by the LED, each of the slots on the scanning mask and the incremental disc creates on the photoelectric sensor a pulse of light similar to a triangle. The shape and thus the fundamental and harmonic content of the triangular shaped individual pulses are to a large degree identical. In the case of **LowHarmonics®** technology, contrary to the usual incremental encoders in which the slots on the incremental disk and the mask have the same period, the periods of the mask slots are shifted such that each uneven harmonic contained in the triangular shaped light pulses encounters a partner shifted by exactly 180°, and thus is cancelled out by **interference**.

- The effectiveness of this process is shown in a **frequency analysis (FFT)** of a HÜBNER LowHarmonics® Sinus-Tacho (➔ Figure 13). In comparison to this device, normal sinewave encoders have particularly pronounced 2nd and 3rd harmonics (➔ Figure 14).

Due to the nature of the principle of operation, a small number of slots can be used with the HÜBNER LowHarmonics® technology. For a given area of the photo-sensitive device, this makes it possible to realize also:

- sinewave encoders for very high speed drives or
- sinewave encoders with large hollow-shaft (➔ Figure 12).

The **precision of the sinewave signals** is shown by displaying them on an x/y oscilloscope (➔ Figure 15):

- Is the Lissajous figure circular?
(Information on the similarity of the sine and cosine amplitudes, 90° phase shift, harmonic content, noise).
- Is the centre of the circle in the correct place? (Information on DC offset).

The influences of errors were investigated in more detail in respect of the precision required. ➔ Figure 16 shows the difference between the nominal and actual angle, if

1. the 2nd and 3rd harmonics are superimposed on the sine and cosine signal, each at 1 % amplitude (-40 dB)
2. the amplitudes of the sine and cosine signals are dissimilar with a difference of 1 %
3. the DC content (DC offset) of the sine or cosine signal is 1 % and
4. the phase shift between the sine and cosine signal deviates from 90° by 1°.

➔ Figure 16 shows for the range -90° to +90° that the harmonics cause the largest error. The other errors, since they are additive, also have a significant effect. These factors are accounted for by HÜBNER and they are given in the HÜBNER data sheets.

Modern controllers recognize dc offset and the difference in the sine/cosine amplitude and correct these errors. This underlines the importance for sinewaves to have negligible **harmonic content** as is the case with HÜBNER **LowHarmonics®** Sinus-Tachos.

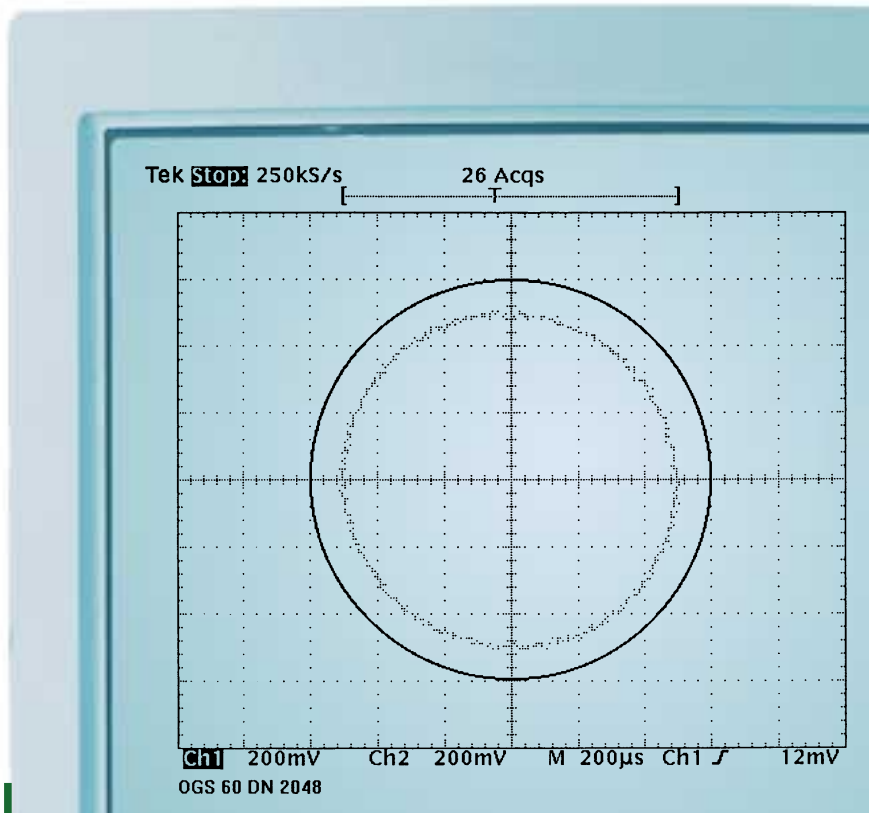

Figure 15: On a x/y sampling oscilloscope LowHarmonics® sine/cosine signals are characterized by a good circular form, as an example the HOGS 60 in a test circle.

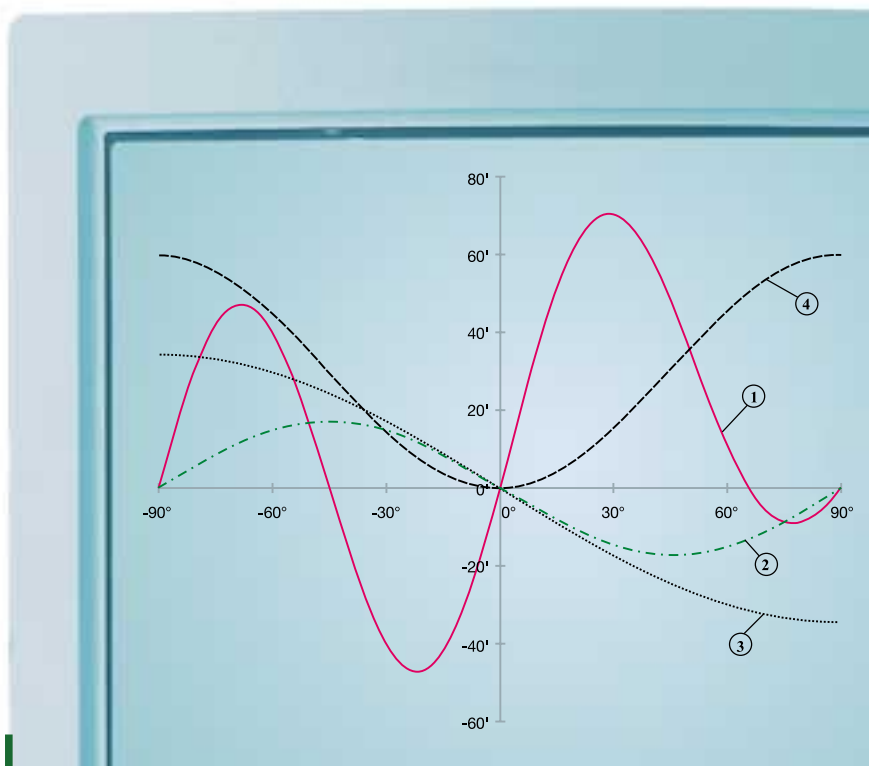

Figure 16: Erroneous sinewave signals cause errors in interpolation: ① harmonics, ② difference in the amplitudes, ③ DC offset, ④ deviation from 90° phase shift.

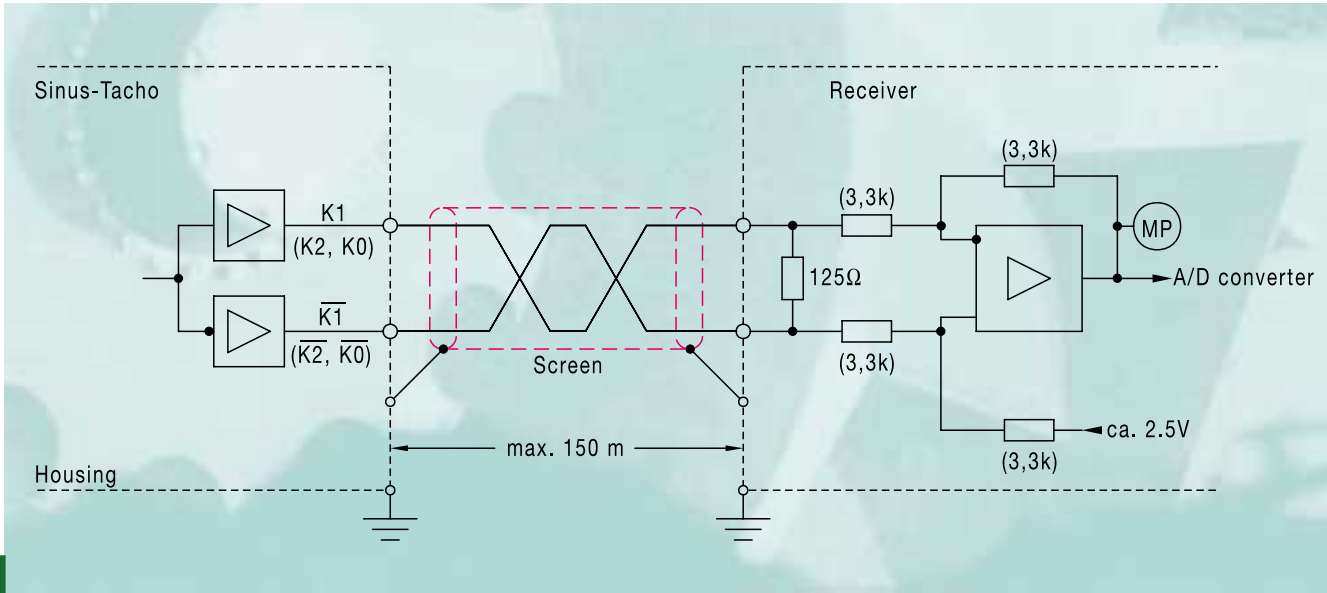

Figure 17: The sinewave signals must be transmitted with care.

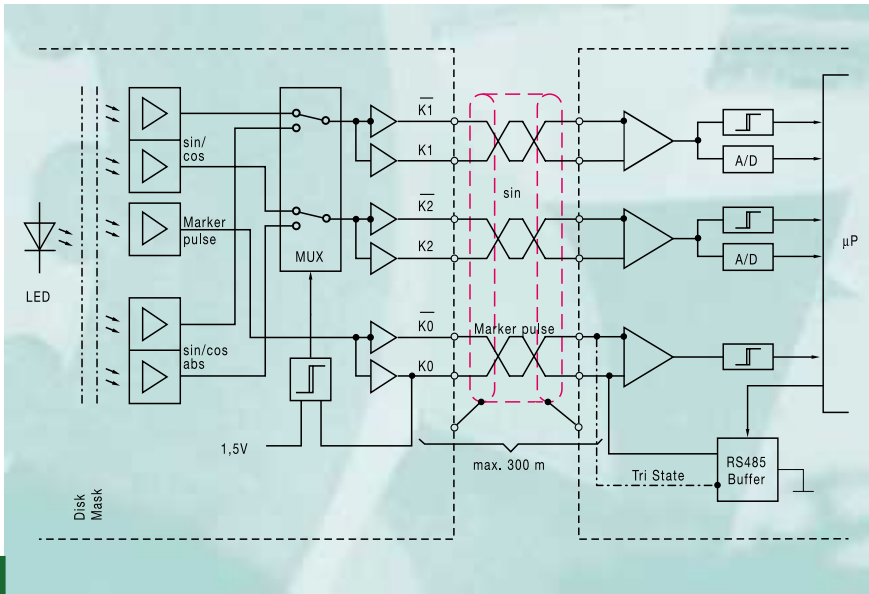

Figure 18: Sinus-Tacho with MUX for transmission of the absolute position.

The **bandwidth** of the opto-electronic scanning is 250 kHz (-3 dB). At 2,048 sinewaves per revolution a speed range of 0 ... 7,300 rpm is achievable. If the amplitude of the sinewave signals is permitted to fall by half (-6 dB), the speed range is increased to approximately 10,000 rpm.

The relatively small sinewave signals of 1 V_{pp} require careful signal transmission (➔ Figure 17, ➔ *Optimum Signal Transmission*, page 24).

For an increased signal to noise margin, an option of 5 V_{pp} sinewave signals is also available from HÜBNER.

More information about the HÜBNER LowHarmonics® technology can be found in our publication „The rest are just noise“.

Sinus-Tachos with absolute track

Sinus-Tachos with an analogue absolute track provide, along with the high resolution LowHarmonics® sine/cosine signals, an additional sine/cosine signal per revolution (more on request) for commutating permanent magnet motors (commutation track). The scanning is executed by brightness modulation similar to a movie sound track.

To minimize the cabling costs the 1 V_{pp} standard version of the device is available with an integral **multiplexer** (MUX), (➔ Figure 18): when the drive is stationary the MUX is switched via the marker pulse channel, the absolute shaft information transmitted over the signal channel, and the MUX subsequently reset to the drawn normal position. In operation the commutation signals are derived with high precision from the marker pulse and the zero transitions of the sinewave signals.

This solution is a cost-effective alternative to single turn absolute encoders.

Sinus-Tachos with rotary acceleration sensor

Digital-Tachos with squarewave or sinewave signals (and also resolvers) are **angular measurement devices** from which the speed can be determined by differentiating the signals over the time. LongLife® dc tachogenerators have an advantage since the tacho voltage follows the speed instantly and with practically no time lag. All errors become more pronounced when differentiating to get speed. It is for this reason that high value was placed on the precision of the sinewave signals in the development of HÜBNER **LowHarmonics®** Digital-Tachos.

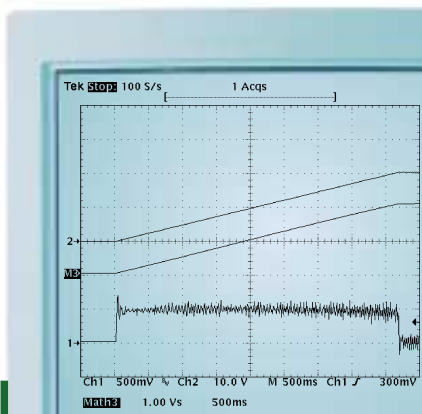

Figure 19: Increase of speed from 0 to 2 000 rpm at an acceleration $\alpha = 50 \text{ rad/s}^2$: Voltage from a LongLife® dc tacho (2), Signal from the HÜBNER angular acceleration sensor (1), Integrated angular acceleration signal (M3).

To control the speed of precision drives, HÜBNER has developed as a supplement to Sinus-Tachos a contactless **angular acceleration sensor** based on the Ferraris principle. Any **change in the speed**, that is acceleration α (dn/dt), provides a signal (➔ Figure 19).

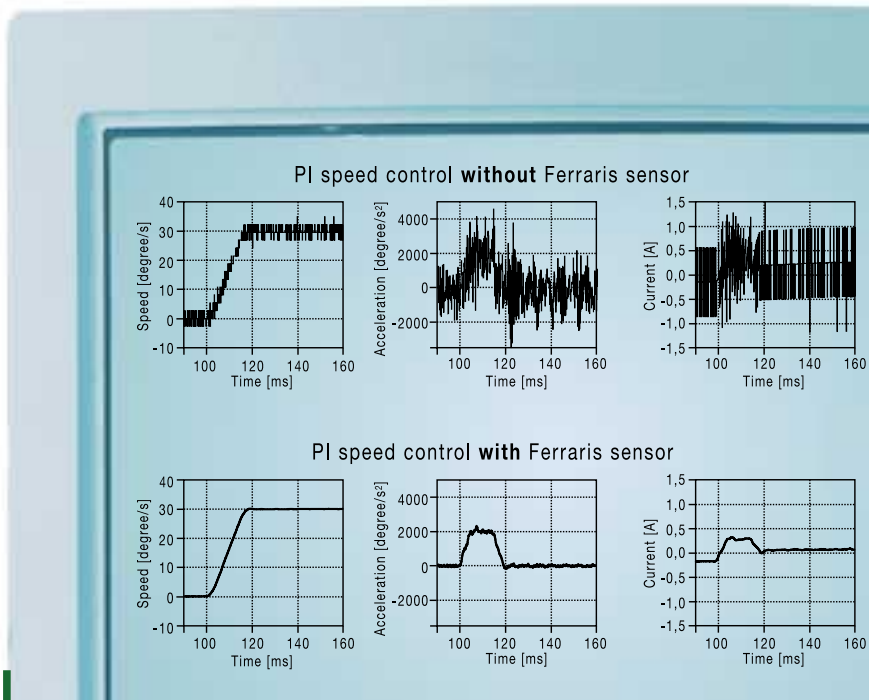

Figure 20: Control of a servo motor at a speed of 5 rpm with and without rotary acceleration sensor (wt Werkstattstechnik 11/12-98, page 478).

HÜBNER **ExtendedSpeed®** angular acceleration sensors are not subject to the usual speed limits that affect Ferraris angular acceleration sensors. This is because the power losses caused by eddy currents remain small due to a new scanning technique for which a patent application has been made.

HÜBNER **ExtendedSpeed®** angular acceleration sensors are available as independent devices for fitting directly to the measured shaft (high resonance frequency). Their rear can be adapted to carry a sinewave encoder. Signal transmission is performed as with the **LowHarmonics®** Sinus-Tachos using a differential technique. Similar care should be taken on cable layout and other aspects (➔ *Optimum Signal Transmission*, page 24). Linear acceleration sensors with the same function principle are also in our programme.

Please, ask for more information about „Angular acceleration sensors“.

Absolut-Tachos (Absolute Encoders)

In the rugged die-cast housing of the POG 10 incremental encoder with EURO-flange® B10 and $\varnothing 11 \text{ mm}$ shaft, HÜBNER has fitted the **AMG 10** absolute multi-turn encoder which counts position to 8,192 steps (13 bit) per revolution and up to 4,096 revolutions (12 bit).

The absolute **position**, 25 bit in sum, is transmitted as digital Gray code to the receiver over a synchronous serial interface (SSI) with TTL level (RS-422), starting with the most significant bit (MSB). Alternatively, an EnDat interface is available.

For **speed control** sine / cosine signals with 512 cycles per revolution and a signal level of $1 V_{pp}$ are available. An option $5 V_{pp}$ signal level may be ordered for very harsh environments.

Other absolute encoders, especially with large hollow-shaft, are in preparation. Please, consult factory.

Supply voltage

The correct supply voltage is important for the precise operation of the Digital- and Sinus-Tacho:

- **HTL technology** does not place any special requirements on the stability and ripple content of the supply (battery) voltage $V_B = +9 \dots 30 \text{ V}$
- **TTL technology** requires $V_B = +5 \text{ V} \pm 5 \%$. Attention must be paid to the voltage drop on the **power supply wires** due to the signal load currents. If necessary sensor wiring be provided to feed back the actual voltage at the Digital-Tacho.
- The **TTL technology, version R**, solves the problem of voltage drop on the supply wires by reducing the supply voltage $V_B = +9 \dots 26 \text{ V}$ to TTL level using a **voltage regulator** installed in the Digital-Tacho (➔ Figure 11 on page 11).
- The **sinewave technology** requires $V_B = +5 \text{ V}$, or $V_B = +9 \dots 26 \text{ V}$ for the version R. The **reference voltage** of $+2.5 \text{ V}$ (➔ Figure 4 on page 8) is necessary for the precise transmission of the sinewave signals is stabilized internally.

Reverse polarity protection

All HÜBNER Digital- and Sinus-Tachos are on principle equipped with reverse polarity protection:

- **HTL, HTL (version C), TTL (version R)** and **sinewave (version R)** devices have a reverse polarity protection diode in the power supply line (➔ Figures 7, 8 on page 10, ➔ Figure 9, 11 on page 11).
- **TTL** and **sinewave** devices have a **suppression diode** fitted in parallel with the power supply terminals that short circuits the supply voltage in the event of reverse polarization (➔ Figure 10 on page 11). The power supply should therefore be equipped with a current limiter.

Protection from voltage spikes

Protection from voltage spikes is provided on all Digital- and Sinus-Tachos:

- Voltage spikes on the power supply wires are suppressed by **interference suppression capacitors** connected in parallel with the power supply terminals (➔ Figures 7 to 11 on page 10 and 11).
- In the case of HTL, voltage spikes on the signal wires are clipped using **recovery diodes** (➔ Figures 7, 8 on page 10).
In the case of HTL (version C), the recovery diodes are integrated in the line driver IC.
- In the case of TTL and sinewave, the **suppression diode** limits the voltage spikes on the supply (battery) voltage V_B .

Electromagnetic Compatibility (EMC)

The Electromagnetic Compatibility of the devices complies with the regulations of the EMC Directive. This is demonstrated

by a **certificate** from an accredited EMC test house for the **HOG 10** Digital-Tacho:

- **EN 50 081-2**
(Emission of Interference)
- **EN 50 082-2**
(Susceptibility to Interference)
 - **EN 61000-4-2**
(Electrostatic Discharges to the Housing)
 - **EN 61000-4-4**
(Fast Transients on Signal and Data Lines)
 - **EN 61000-4-5**
(Voltage Transients on Signal and Control Lines).

HÜBNER Digital-Tachos are tested for resistance to voltage transients using the measurement bench shown in ➔ Figure 21: the electronics in the Digital-Tacho must withstand voltage spikes of up to 4 kV capacitively coupled onto the cable cores over the 1 m long test run. The transmission of signals to the receiver is also tested and optimized under the same conditions.

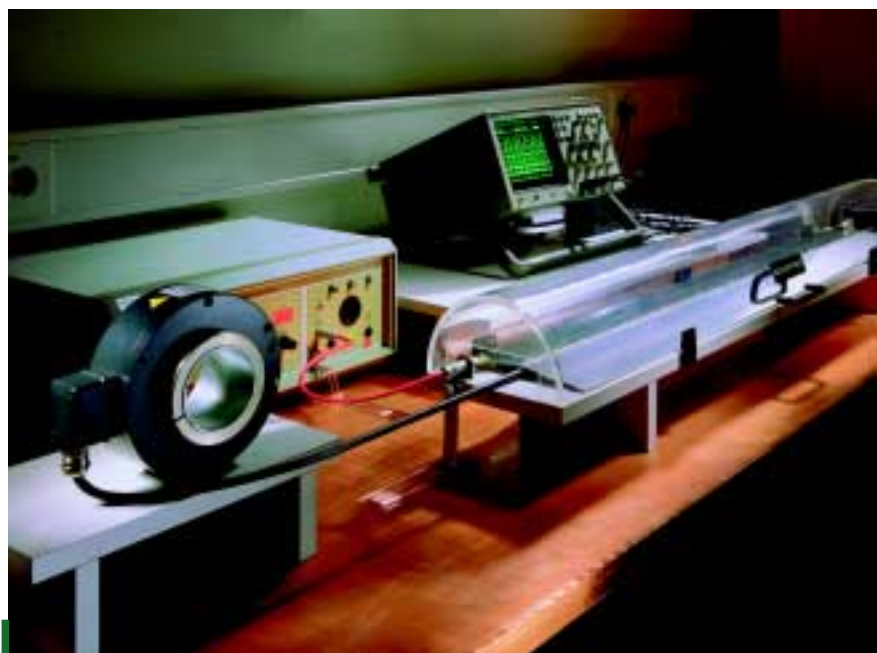

Figure 21: Measurement bench for voltage transients for optimizing Electromagnetic Compatibility (EMC).

Housings

HÜBNER housings are die-cast or machined light alloy for ruggedness (no plastics with poor EMC performance), (➔ Figure 22). Housings of stainless steel are available for some devices.

The **size** of the **housing** should correspond to the application:

- Large driving machines require a Digital-Tacho of **adequate size** (➔ *Typical applications* on page 26).
- For use in maritime or particularly damp or humid climates, the devices can be provided with optional **protection against maritime climates and tropicalization**.

We will be pleased to give you **advice** on all design and planning matters.



Figure 22: **HeavyDuty® technology** in top form: solid alloy housing, generously sized, insulated ball bearings, scanning electronics with power transistors mounted between the bearings, labyrinth seal for protection class IP 66 (HOG 10).

Ball bearings

The lubricated for life ball bearings are generously sized for high vibration and shock resistance and are in many cases taken from the proven LongLife® dc tachogenerators. Vibration, shock, temperature,

angular acceleration, reversing, etc. have a strong influence on the life time. The **maximum speed** n_{\max} must not exceed the value given in the data sheets. Normally, this value is lower with devices with hollow-shaft. If necessary, "Digital-Tachos without bearings" (➔ page 19) should be used.

The ball bearing manufacturers state the following relationship for nominal **life time** (number of revolutions) which is reached or exceeded by 90 % of all bearings:

$$L = \left(\frac{C}{P}\right)^3$$

- L: Number of revolutions
- C: Dynamic load rating (N)
- P: Bearing load (N)

● Example:

For a HÜBNER hollow-shaft Digital-Tacho with bearings at both ends, the ball bearings of which each carry half the weight of the tacho of, e.g., 1 kg, the following can be applied

- C (typical value) = 9,000 N
- P (typical value) = 5 N
- ➔ $L = 5.8 \times 10^9$ revolutions.

This value matches practical experience well: In paper making machines HÜBNER Digital-Tachos have achieved a ball bearing life time of 40,000 hours at a rotational speed of 2,500 rpm which corresponds to 6×10^9 revolutions.

The nominal value stated in HÜBNER data sheets of **10⁹ revolutions** is considerably exceeded under normal conditions.

Bearings at both ends

The incremental disk mounted between the bearings is used as a matter of preference when technically possible due to the higher radial and axial load carrying capacity. This also offers the possibility of integrating a second device using a single shaft (➔ *Combinations Expand the Range of Applications* on page 23).

Rear shaft

On the majority of devices with bearings at both ends, an optional rear shaft is available for the installation of further devices.

Protection from shaft currents

Voltage differences may occur in the rotor of motors larger than 100 kW or operated by fast switching frequency converters (➔ Figure 24). They create shaft currents which from a current density of approx. 1 A/mm² can cause damage to the surfaces of ball races (➔ Figure 23).

The following conditions can cause this effect:

- Asymmetry in the magnetic circuit
- Capacitive coupling by fast frequency converters
- External voltages of driven machines
- Electrostatic charges by v-belts or lubricants
- Unipolar voltages generated in sleeve bearings.



Figure 23: Ball bearings damaged by shaft currents are characterized by a corrugated ball race surface.

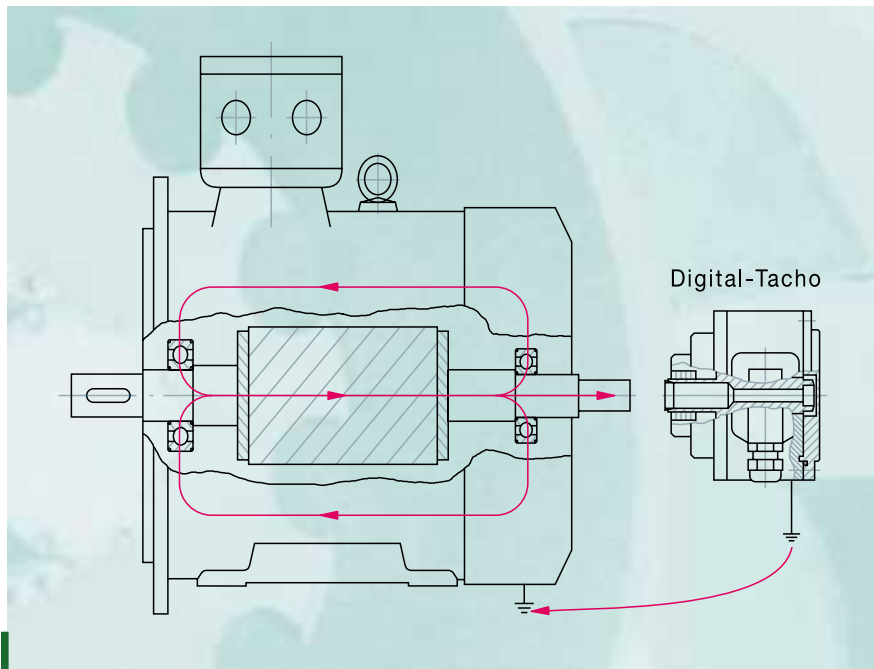

Figure 24: Voltage differences between each end of the rotor create shaft currents which if the rear ball-bearing is insulated, endanger the built-on components.

As protection against shaft currents modern motors are equipped with an insulated ball-bearing at the rear end. Thus, the problem is transferred to the built-on devices (➔ Figure 24).

The latest generation of rugged HÜBNER hollow-shaft Digital-Tachos are equipped with **insulated ball-bearings** for protection against shaft currents (➔ Figure 22). Maintaining the earth contact is very important to meet Safety Regulations (➔ page 24).

Solid shaft Digital-Tachos (and Analog-Tachos) can be protected from shaft currents by using the HÜBNER K 35, K 50 or K 60 spring disk couplings with **insulated hub**.

Another variant is shown in the HOG 161 Digital-Tacho which can be fitted with an optional integral, patent pending **sliding earth contact** and silver track as per HÜBNER LongLife® Technology. This contact carries capacitive currents to „earth“ bypassing the ball bearings of the drive and the Digital-Tacho.

Further information about *Shaft Currents* can be found in our special publication „Protecting Rotary Sensors by fitting Insulated Ball Bearings“.



Figure 25: Digital-Tachos HG 18 without bearings synchronize two DC gear motors coupled by a cardan shaft.

Digital-Tachos without bearings

HÜBNER has available Digital-Tachos without bearings for drives with large axial backlash (➔ Figure 25) or high top speed. An axial displacement of ± 2 mm or speeds up to 18,000 rpm are permissible, depending on the version.

Temperature range

The information given in the data sheets on the temperature range refers to the temperature on the surface of the housing on the rear side. The range corresponds to the application class and is either -20 °C to $+70\text{ °C}$, -20 °C to $+85\text{ °C}$, or -20 °C to $+100\text{ °C}$. The **internal temperature** of the Digital-Tacho (heating of the ball bearings and the seals at high rotational speeds, power loss of the line drivers and the internal voltage regulator in the case of option R) must be taken into consideration (➔ *Power loss* on page 12).

Vibration and shock resistance

Vibration and shock resistance depends on the design of the respective Digital-Tacho and is specified in the data sheets:

- IEC 68-2-6 »Vibrations, Sinewave«
- IEC 68-2-27 »Shocks«
- IEC 68-2-29 »Repeated Shocks«.

During the development phase HÜBNER optimizes the resistance of the assembled printed-circuit boards using a measuring bench which is continually variable in frequency and amplitude (➔ Figure 26 on page 20). Special attention is paid to the resonant frequencies of the individual components. The acceleration values that occur are recorded by a low mass acceleration transducer.

A certificate from an accredited test house about successfully passed vibration and shock tests is available on request for the Digital-Tachos **POG 9** and **POG 10**.

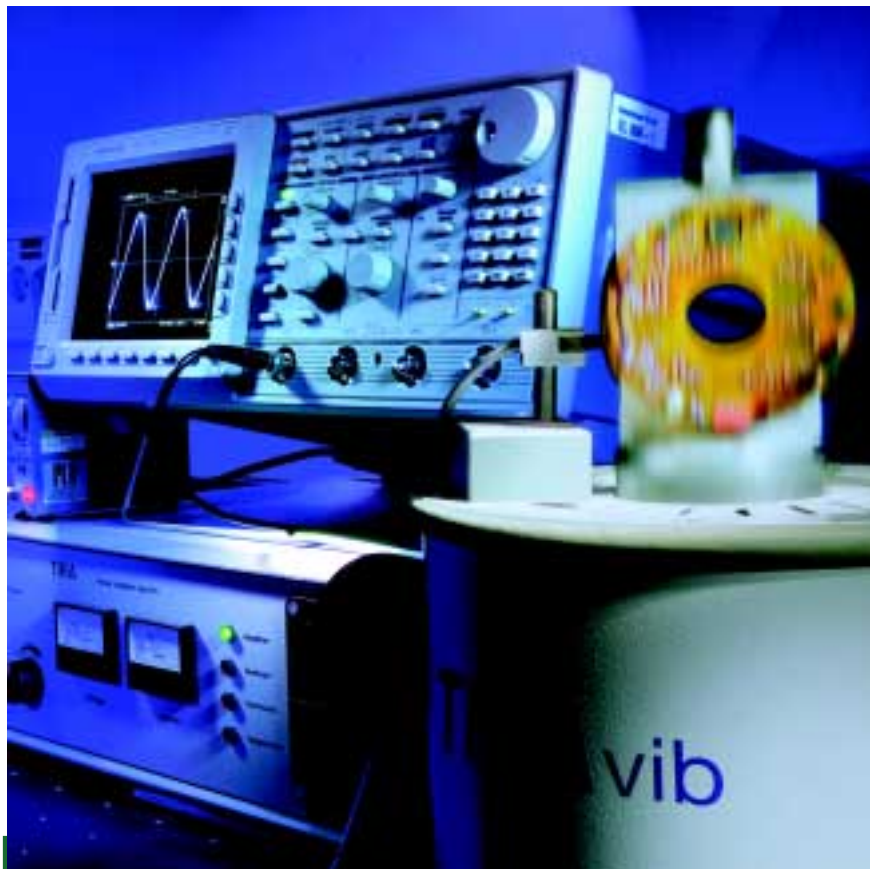

Figure 26: Vibration testing of a pc-board in the frequency range 2 Hz to 4 kHz on a vibrating bench with air suspension.

Protection class

The IP (International Protection) in accordance with **EN 60034-5** and **IEC 34-5** (Subdivision of Protection Classes by Housing) is fundamental in selecting a Digital-Tacho and is stated in the data sheets as follows:

- **1st digit** (Protection from Ingress of Foreign Bodies):
 - 5 = Protection from damaging dust deposit (dust protected)
 - 6 = Protection from entry of dust (dust tight)
- **2nd digit** (Protection from Ingress of Water):
 - 4 = Protection from water spray
 - 5 = Protection from water jets
 - 6 = Protection from inundation.

HÜBNER considers the protection class very important. The HOG 10, as an example, was developed with a specific sealing system for high protection class IP 66.

Cable connection

The options available for cable connection depends on the device and the application class:

- Terminal box with Combicon® terminals and terminal cover reversable by 180° for cable outlet on the right or left of the unit
- Internal terminal strip
- Metal-bodied mating connector
- Flying lead.

The cable should have the same diameter as that given in the data sheets in order that the **cable fitting** (cable gland) can meet the protection class.

The new European standard

EN 50 262 – Metric cable glands for electrical installations

replaces the previous steel conduit thread PG by the **metric ISO fine-thread**.

The cable screen should be connected to the cable gland so that it forms a good electrical contact. Special attention should be paid to **earthing the device** (➔ *Optimum Signal Transmission*, page 24).

EURO-flange® B10

HÜBNER offers the widest range of products on the market featuring the internationally standardized EURO-flange® B10:

- Digital-Tachos
- Analog-Tachos
- Mechanical / electronic overspeed switches
- Combinations of these devices with continuous shaft (➔ page 23).

Please ask for the special leaflet **“EURO-flange® B10”**.

Explosion proof

The German Federal Institute of Standards (PTB) has confirmed with the Declarations of Conformity that the Digital-Tachos **EEx OG 9** and **EEx HOG 161**, in accordance with

- **EN 50 014** *General Definition*
- **EN 50 018** *Explosion proof enclosure “d”*
- **EN 50 019** *Increased safety “e”*

are approved for operation with standard industrial cabling in hazardous areas, code **“EEx de IIC T6”**.

Both devices are available with high precision **sinewave signals** as option.

ISO 9001

We would be pleased to provide you with a certified copy of the **ISO 9001 certificate** from TÜV CERT for your quality management system.

EU Declaration of Conformity · CE

We would be pleased to send you the Manufacturer's Declaration that our products meet the European Directive **89/336/EWG** (Directive on Electromagnetic Compatibility, ↻ page 17).



Figure 27: HÜBNER spring disk couplings with insulated hub protect against shaft currents.

Coupling

The coupling between the drive and the Digital-Tacho or the Sinus-Tacho is decisive for the precision of the acquisition of the actual value:

- Devices with **solid shaft** should be connected to the shaft of the drive using a coupling free of torsion and backlash. HÜBNER offers suitable spring disk couplings K 35, K 50, K 60 in the product range (↻ Figure 27).
- The coupling must be slid onto the tacho shaft **without the application of force** to avoid subjecting the precision ball bearings to any uncontrolled axial pressure. The sticker "crossed out hammer" is used to draw attention to this point.
- **Parallel, angular and axial displacement** (shaft offset, alignment error) are to be kept as small as possible in the interests of high transmission precision (↻ Figure 28). The version with an insulated hub is to provide protection against **shaft currents**.

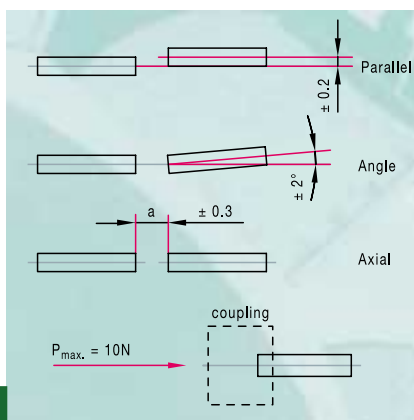

Figure 28: Parallel, angular and axial displacement should be as small as possible.

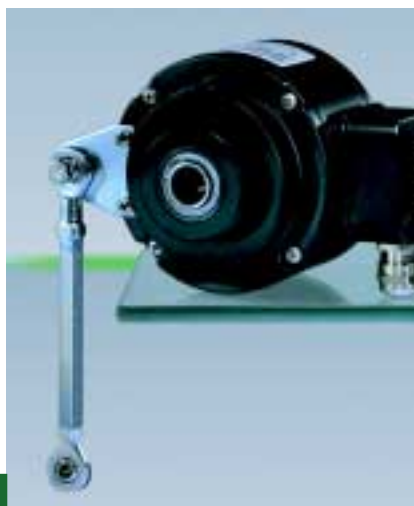

Figure 29: The torque arm should be fitted as perpendicular as possible (HOG 10).

- Devices with **hollow-shaft** are slid directly onto the shaft of the drive motor and firmly tightened to it. Changes in speed are transmitted directly to the hollow-shaft of the Digital-Tacho. HÜBNER offers a large number of different fixing methods for hollow-shafts. These are adapted to suit the application of the drive.
- The **torque arm** absorbs the reaction torque of the ball bearings and prevents the housing rotating with the shaft:
- HÜBNER torque arms with ball joints are to be fitted without placing them under any stress and as **tangential** ($90^\circ \pm 30^\circ$) to the Digital-Tacho as possible (↻ Figure 29).

- Smaller Digital-Tachos are fitted with a stator coupling, spring steel plate or pin for torque restraint.
- Devices with an **internal stator coupling** can be fitted directly on the drive motor. This leads to a rugged, compact design.
- Stator couplings offer the highest precision of all torque arm methods and the highest resonant frequency.

■ The **spring-mass system** comprising the coupling and the shaft (including the inner race of the ball bearing and the incremental disk) of the Digital-Tacho or the Sinus-Tacho has a **resonant frequency f_R** in a closed loop control system that should be as high as possible:

$$f_R = \frac{1}{2\pi} \sqrt{\frac{C_{T \text{ dyn}}}{J}}$$

- f_R : Resonant frequency (Hz)
- $C_{T \text{ dyn}}$: Torsional rigidity of the coupling (Nm/rad)
- J : Moment of inertia of the encoder shaft (kgm^2)

The values are given in the data sheets.

- Example:
 - Coupling K 35:

$$C_{T \text{ dyn}} = 900 \text{ Nm/rad}$$
 - Digital-Tacho OG 9:

$$J = 280 \text{ gcm}^2$$

$$\rightarrow f_R = 900 \text{ Hz.}$$