

HÜBNER
ELEKTROMASCHINEN AG
BERLIN

Amicon
AMERICAN INDUSTRIAL CONTROLS INC.

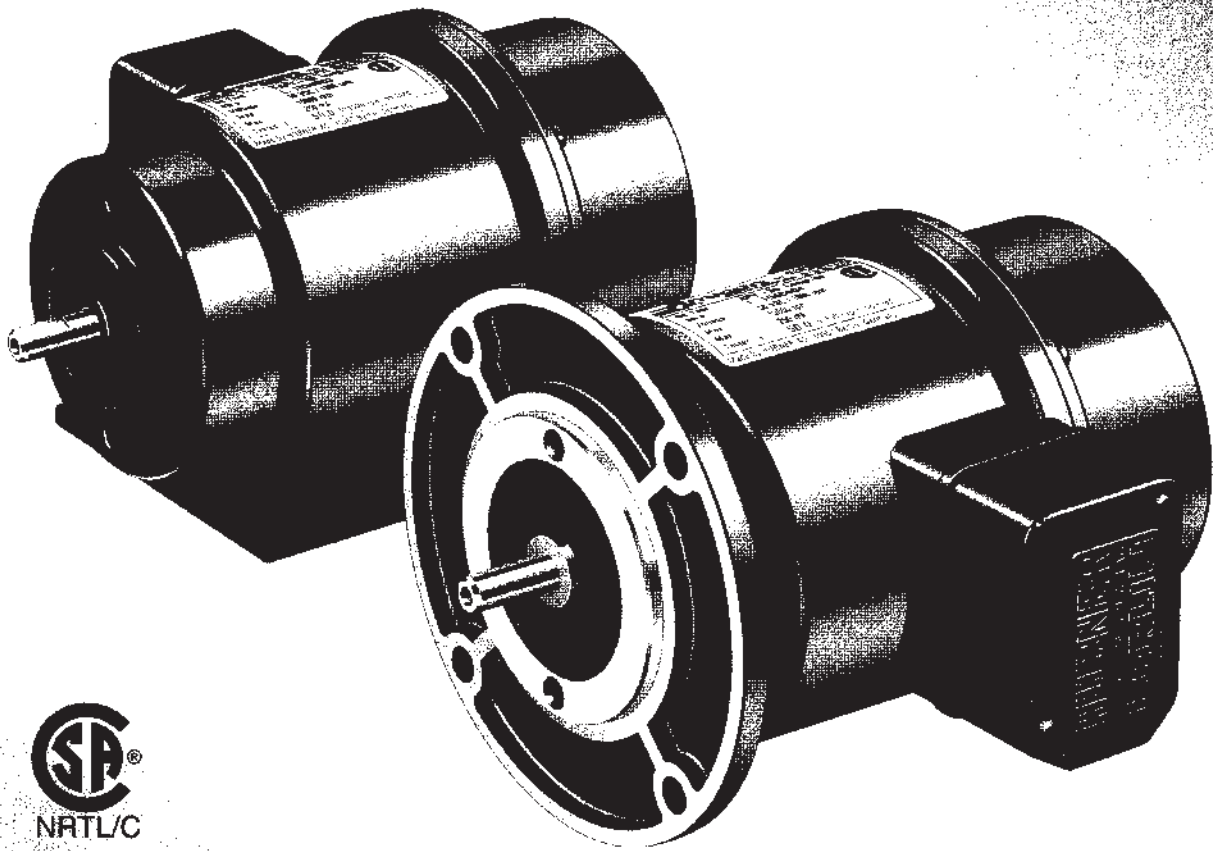

APY
FAPY

LongLife DC Tachometers



APY / FAPY TACHOMETERS

LongLife DC Tachometers in industrial NEMA 12 housings are available with flange or foot for mount for direct replacement of "PY" or "BC" style tachometers. These tachometers are CSA / NRTL/C approved.

50 or 100 VDC / krpm outputs are available with regulation of 1% or .1% for precise speed control in all applications.

HÜBNER, Europe's leading technological manufacturer of tachometers, presents the LongLife Technology, resulting in the best tachometers available in the world. A patented design and process imbeds a silver track in the commutator. The result is high precision output, low ripple and a brush/commutator life that exceeds that of the precision ball-bearings ($\geq 10^9$ revolutions).

Type	no-load voltage 1,000 rpm	max. load current	max. speed rpm	Enclosure	Temperature range
APY 50	50V	80 mA	10,000	IP 55	-30 °C...+130 °C
APY 100	100V	40 mA	6,000		
FAPY 50	50V	80 mA	10,000		
FAPY 100	100V	40 mA	6,000		

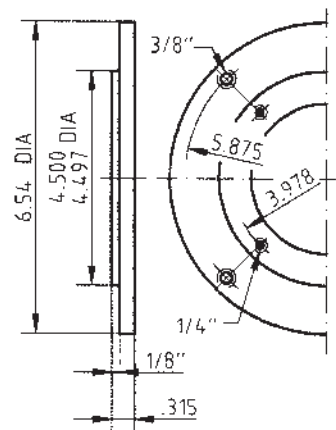
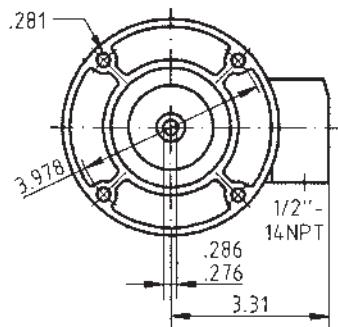
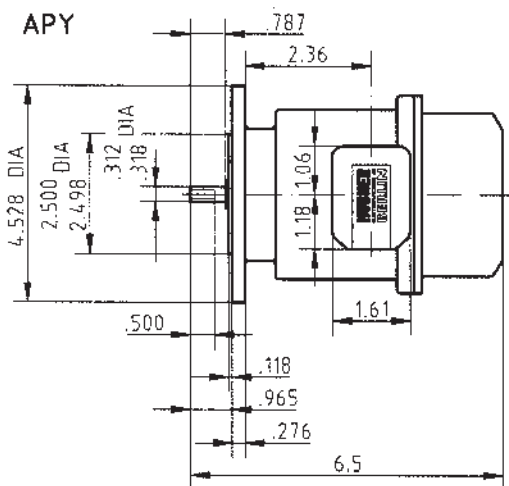

BC Adapter

