

Main features

EM series encoders well suit several application fields like electric motors, marine industry, iron and steel industry, textile machines, wood-working, paper-working, glass-working, marble-working machinery and, more generally, automation and process control fields.

- Compact dimensions
- Absence of physical contact between encoder and motor shaft
- High temperature resistant
- High resolution and precision
- High enclosure rating
- High working speed
- Excellent mechanical robustness
- Very easy mounting



full stop to separate special versions

EM	A	22	A	400	B	5	P	P	X	6	S	10	PR	.	XXX
magnetic encoder EM	absolute A sinusoidal S	size 22											PR radial cable output (standard length 0.5m)		special version code numbered from 001 to 999
Type of flange															
standard A															
Resolution															
(EMA series) p.p.r. 400 / 500 / 800 / 1000 1600 / 2000 / 1024 / 2048 / 4096 / 8192															
(EMS series) p.p.r. 1															
Code type (EMA series)															
binary B Gray G															
Power supply															
5 VDC 5															
Output type															
SSI (EMA series) S push-pull parallel (EMA series) P sine - cosine (EMS series) L															
Options															
X to be indicated if not used ZE programmable zero pulse (EMA series)															
Logic (EMA series)															
P positive N negative															
Max. rotation speed															
10 10000 RPM															
Enclosure rating															
S IP68															
Bore diameter (magnet-carrier)															
6 ø 6 H7 mm 8 ø 8 H7 mm 9,5 ø 9.52 H7 mm 10 ø 10 H7 mm															

EMA - EMS 22

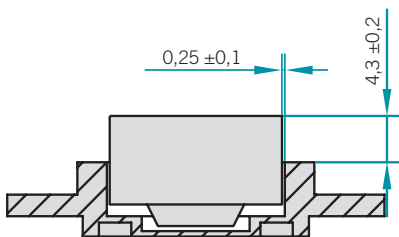
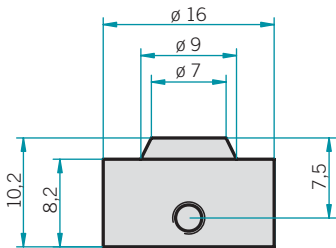
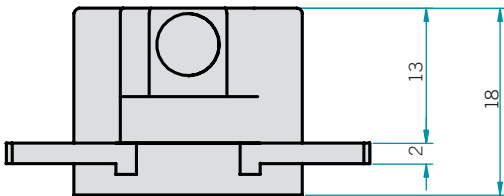
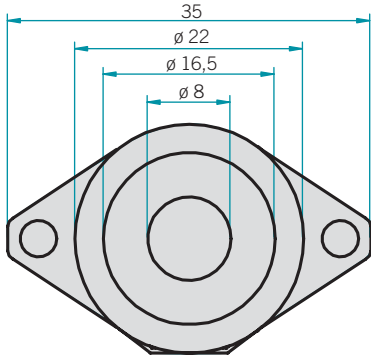

Electrical specifications

Resolution	absolute SSI up to 8192 p.p.r. absolute parallel up to 8192 p.p.r. sine - cosine (1 sin./turn)
Current consumption without load	100 mA max.
Max. load current	15 mA for channel
Power supply	5 VDC ± 5%
Output types	sine - cosine (EMS series) push-pull parallel (EMA series) SSI (RS422A) (EMA series)
Max. output frequency	200 kHz
SSI transmission frequency	70 ÷ 1000 kHz (EMA series)

Mechanical specifications

Bore diameter (magnet-carrier)	up to 10 mm
Enclosure rating	IP68
Max. rotation speed	10000 RPM
Shock	50 G, 11 ms
Vibration	10 G, 10 ÷ 2000 Hz
Body material	aluminium D11S UNI 9002/5
Housing material	aluminium D11S UNI 9002/5
Magnet-carrier material	aluminium D11S UNI 9002/5
Operating temperature	-25 ÷ 125 °C
Storage temperature	-30 ÷ 130 °C
Weight	30 g
Mounting tolerances	axial: ±0,2 mm radial: ±0,1 mm

