



EL / EF 49C-P

EL incremental encoders / EF incremental encoders + commutation phases

Incremental encoders for motor

The encoders of the "49" series are applied on systems of retroaction on AC servomotors; they integrate more than a traditional incremental encoder, the optic generation of "Hall effect phases".
The main characteristics are :

- Interchangeability with the Size 19 resolver, saving time and money, as it is necessary to have only one predisposition for the retromotor
- Easy mechanical assembly
- Simplification of the wiring through the use of a connector kit
- Contained dimensions
- High temperatures resistance
- Wide range of resolutions available

Serie EL

Base version with incremental encoder
Availability of various electronic output configurations.

Serie EF

Optic generation of the "commutation phases" integrated to the base version. The transmission of signals happens in a parallel way.



General electronic characteristics

Resolution imp./turn	From 1 to 2048
Source and Sink current	15 mA per channel with Line Driver 30 mA per channel with other electronics
Max output frequency	MAX 150KHz $F = \frac{R.P.M. \times Resolution}{60}$

"EL" Electronic characteristics

Power Supply	5 Vdc / 8+24 Vdc
Available Electronics	NPN / NPN OPEN COLLECTOR / PUSH PULL / LINE DRIVER
Current consumption without load	100 mA

"EF" Electronic characteristics

Power supply	5Vdc ± 5%
Electronics for incremental phases	LINE DRIVER
Electronics for Hall effect phases	LINE DRIVER / NPN OPEN COLLECTOR
Current consumption without load	150 mA

Signal configurations

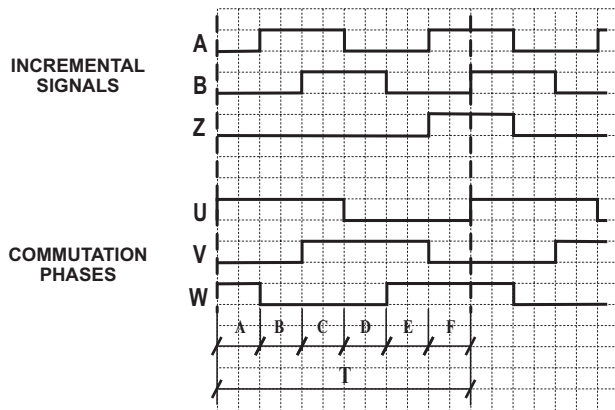

N° POLES	A / B / C / D / E / F	T
4	$30^\circ \pm 1.5^\circ$	180°
6	$20^\circ \pm 1.5^\circ$	120°
8	$15^\circ \pm 1.5^\circ$	90°

Mechanical Characteristics

Hole diameter	$\varnothing 6 / \varnothing 8 / \varnothing 10 / \varnothing 12 / \varnothing 12.7(1/2") H7$
R.P.M.	6000 MAX
Shock Vibrations	50 G per 11 msec 5G 10 + 500 Hz
Bearings	n° 2 ball bearings
Shaft material	Stainless Steel
body material	Aluminium
cover material	Fe
Weight	100 g
Protection	IP40
Operating temp.	-10° + + 100°C
Storage temp.	-25° + + 100°C
Accessories	<ol style="list-style-type: none"> Set of 3 servo fasteners ordering code: 94080001 Flange for fixage on the predisposed motors "Resolver" size 19 version 01 and 14 (for dimensions see the back)

EL-EF49 C/P

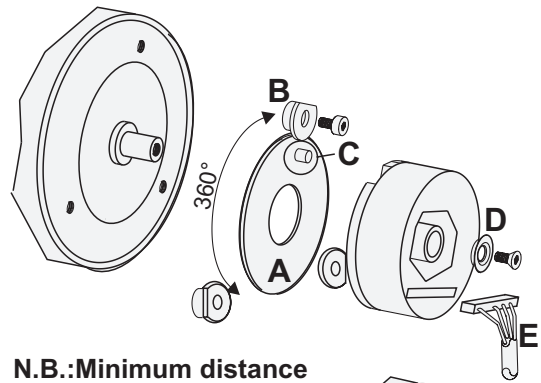
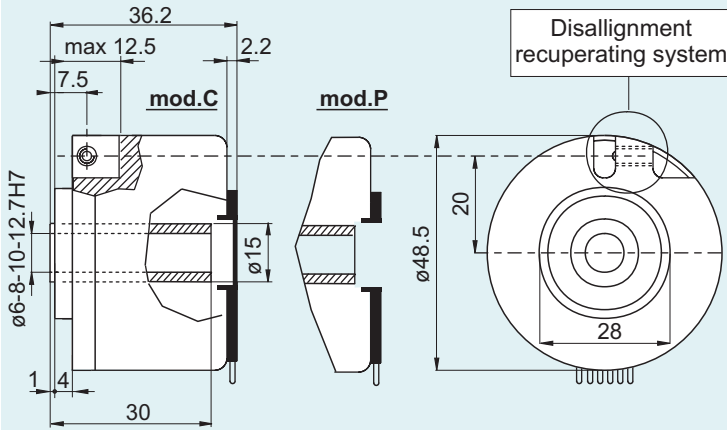

N.B.: Minimum distance encoder-flanges > 0.5mm

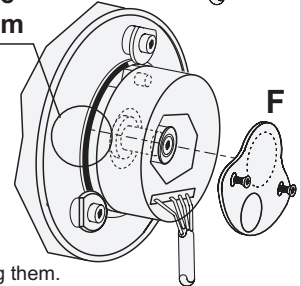

Accessories: Flange for the fixing on the motors

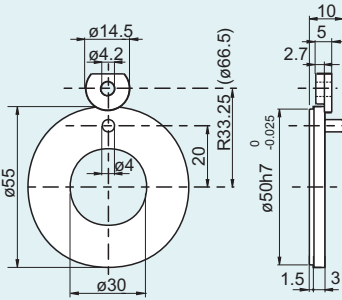

Predisposition
"Resolver" size 19 version 01
Ordering code : **FLG000**

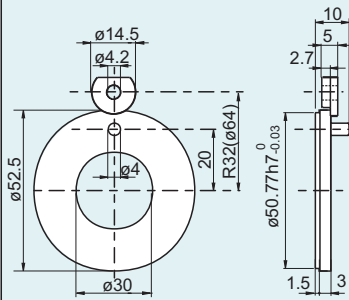

Predisposition
"Resolver" size 19 version 14
Ordering code : **FLG001**

How to install the encoder

- 1) Insert the flanges (A) on the motor.
- 2) Tighten the appropriate servo fasteners (B), without blocking them.
- 3) Insert the encoder on the motor shaft with the system of disallineament recuperation corresponding to the pegs (C). The minimum encoder-flange distance must be bigger than 0.5mm.
- 4) Insert the washer posteriorly (D) and block it using the screw of the encoder on the motor axle.
- 5) Turn for phasing
- 6) As final operation fix the servo fasteners (B). Check that the system to recuperate the disallignment works correctly
- 7) Insert the connector (E) and position the plastic lid (F) corresponding to the holes and then screw them in.

Ordering Code

EF 49 C 6 L 2000 Z 5 L 8 X 6 LR . XXX

In case of particular Customer variant separate by a full stop

EL = incremental encoder
EF = incremental encoder + commutation phases

49 = body dimension

C = with blind hole
P = with through hole

N.B.: TO BE INDICATED ONLY FOR EF / EW MODELS

4 = n° 4 poles
6 = n° 6 poles
8 = n° 8 poles

N° poles of the motor

C = NPN OPEN COLLECTOR
L = LINE DRIVER

Electronic for phase commutation

from **1** to **2048** imp./turn
Incremental encoder resolutions
N.B.: For impulse availability contact directly our offices

S = without zero impulse
Z = with zero impulse

5 = 5 Vdc
Power supply for the. EF mod.

5 = 5 Vdc
8 ÷ 24 = from 8 to 24 Vdc
Power supply for the. EL mod.

XXX = Special Customer variants indicated by a number from 001 to 999

LR = radial output cable + thickness of cable with standard length 0.2 m
Optional: thickness of wired cable length 1.5 m
MA = radial output cable + thickness of cable with standard length 0.2 m with connector type M 19 poles

6 = 6000 R.P.M. max

X = Protection IP40

6 = ø6H7 mm
8 = ø8H7 mm
10 = ø10H7 mm
12 = ø12H7 mm
12.7 = ø12.7(1/2")H7 mm

Shaft hole diameter

N = NPN
C = NPN OPEN COLLECTOR
P = PUSH PULL
L = LINE DRIVER

Electronics for EL mod.

L = LINE DRIVER
Electronics for EF mod.

For the optionals on the output configurations see the incremental output connections card

